

**CHC SERIES HELICAL
GEAR UNITS**



INTRODUCTION

CHC series helical gear units is a new generation product, which designed basing on the modular system.

It can be connected respectively with motors such as standard motor, brake motor, explosion-proof motor, IECmotor B5 - B14. This kind of product is widely used in drive fields such as textile, foodstuff, beverage, chemical industry, packaging and so on.

PRODUCT FEATURES

- Modularity
- High efficiency
- Low noise
- Universal mounting
- Aluminum housing, light in weight
- **Gears in carbonize hard, grinded**
- Lubricant maintenance free

CHC Series helical gear units are manufactured in 5 sizes (+ 1 on request). Power 0.12-4 Kw; Ratio 5-46.

Torque max 120-500 Nm. It can be connected (foot, flange) discretionary and use multi-mounting positions according to cutomers' requirements.



ASSEMBLING POSSIBILITY

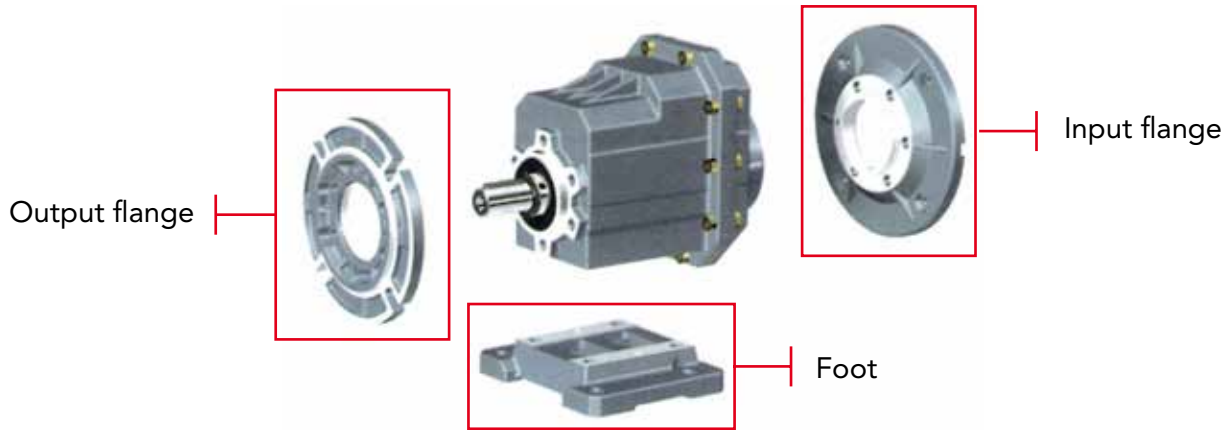

DESIGNATION

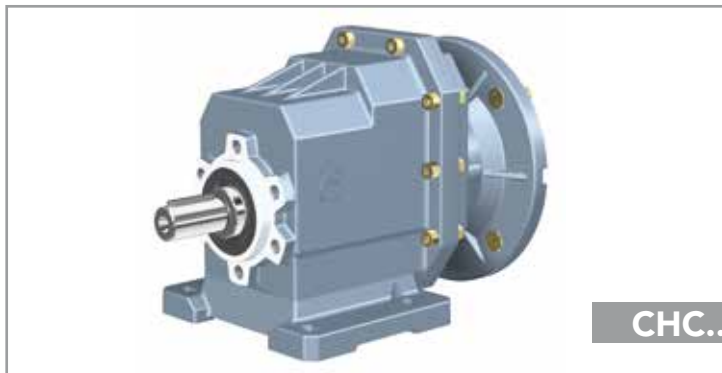

ORDER EXAMPLE
CHC 25PB 28,9 80B5 B3

Type CHC
Size 16*-20-25-30-35-40
The number indicates the output shaft diameter
*CHC 16 on request

Version P foot
F flange
no foot
no flange

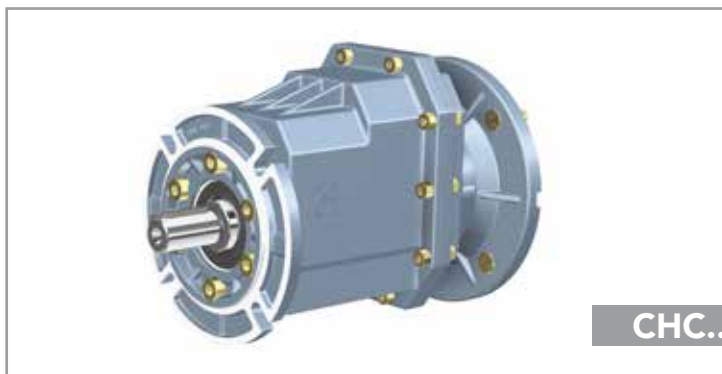

Flange type 1 2 3

Foot type M / B / C

Ratio see catalogue
IEC Motor flange size
Version B5-B14
Mounting position B3-B8-B6-B7
V5-V6-B5-V1-V3

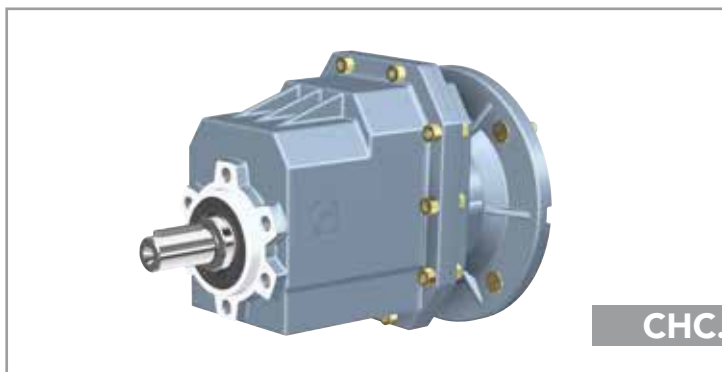

If the motor is also required please specify

Size es. 71B4
Power es. Kw. 0,37
Poles es. 4
Voltage es. 230 / 400
Frequency es. 50 Hz.
Flange es. B5



GENERAL INFORMATION

POWER P

$$P_1 \cdot \eta = P_2$$

P_1 = Input power

P_2 = Output power

η = Transmission efficiency

ROTATION SPEED n

n_1 = Input speed

n_2 = Output speed

An output speed ≤ 1400 rpm is suggested so as to optimize the working condition and extend the service life.

Input speed higher are allowed following the table below.

n. RPM	POWER
1400	Kw
2000	Kw * 1,35
2800	Kw * 1,8

TRANSMISSION RATIO i

$$i = \frac{n_1}{n_2}$$

TORQUE M

$$M_2 = \frac{9550 \cdot P_1 \cdot \eta}{n_2} \text{ [Nm]}$$

$$M_2 \geq M_{2n} \cdot f_s \text{ [Nm]}$$

M_2 = Output torque

M_{2n} = Rated output torque

P_1 = Input power

η = Transmission efficiency

f_s = Service factor

2D and 3D drawings available on the web site www.chiaravalli.com

Quantity, availability and prices with Chiaravalli B2B



RADIAL LOADS F_R

The radial loads is proportional to the requested torque and inversely proportional to the transmission member diameter following this formula.

$$F_R = \frac{2000 \cdot T \cdot T.e.f.}{D} \left[N \right]$$

F_R = Radial load
 T = Nm (Torque)
 $T.e.f.$ = Transmission element factor
 $T.e.f.$ = 1,15 gear
 = 1,4 chain sprocket
 = 1,75 v-pulley
 = 2,5 flat-pulley
 D = Transmission element diameter

When the radial loads is not applied on the centre line of the shaft it is necessary to use the following formula.

$$F_{Rx} \leq \frac{F_R \cdot a}{(b+x)} \left[N \right]$$

F_R = Radial load on the centre line
 a, b, x = see table

CONSTANTS' VALUES

	CHC 16-20	CHC 25	CHC 30	CHC 35-40
a	103	116,5	130	147
b	83	91,5	100	112

Output shaft radial loads & axial loads F_R, F_A

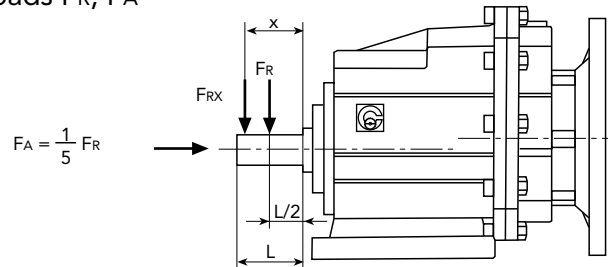

n_2 [min ⁻¹]	10	40	60	80	100	120	150	180	250	400
CHC 16-20	2300	2300	2180	1980	1840	1630	1400	1320	1080	920
CHC 25	4800	4800	4370	3970	3680	3470	2710	2550	2150	1840
CHC 30	6300	6300	5550	5040	4510	3800	3530	3320	2800	2390
CHC 35-40	7500	7500	6590	5990	5230	4570	4240	3900	3350	2860

F_R
[N]



LUBRICATION

TYPES OF LUBRICATION

		ISO	SHELL	MOBIL	BP	Lubrication type
CHC	-10 to +40	VG 220	Shell Omala 220	Mobilgear 630	BP Energol GR-XP 220	Mineral Oil
	-20 to +25	VG 150 VG 100	Shell Omala 100	Mobilgear 627	BP Energol GR-XP 100	
	-30 to +10	VG 68-46 VG 32	Shell Tellus T 32	Mobil D.T.E. 13M		
	-40 to -20	VG 22 VG 15	Shell Tellus T 15	Mobil D.T.E. 11M	BP Energol HLP-HM 15	Synthetic oil
	-40 to +40	VG 150	Shell Omala HD 150	Mobil SHC 629		
	-40 to +60	VG 220	Shell Omala HD 220	Mobil SHC 630		
	-25 to +50	VG 320	Shell Tivela S 320			



MOUNTING POSITION AND TERMINAL BOX ORIENTATION

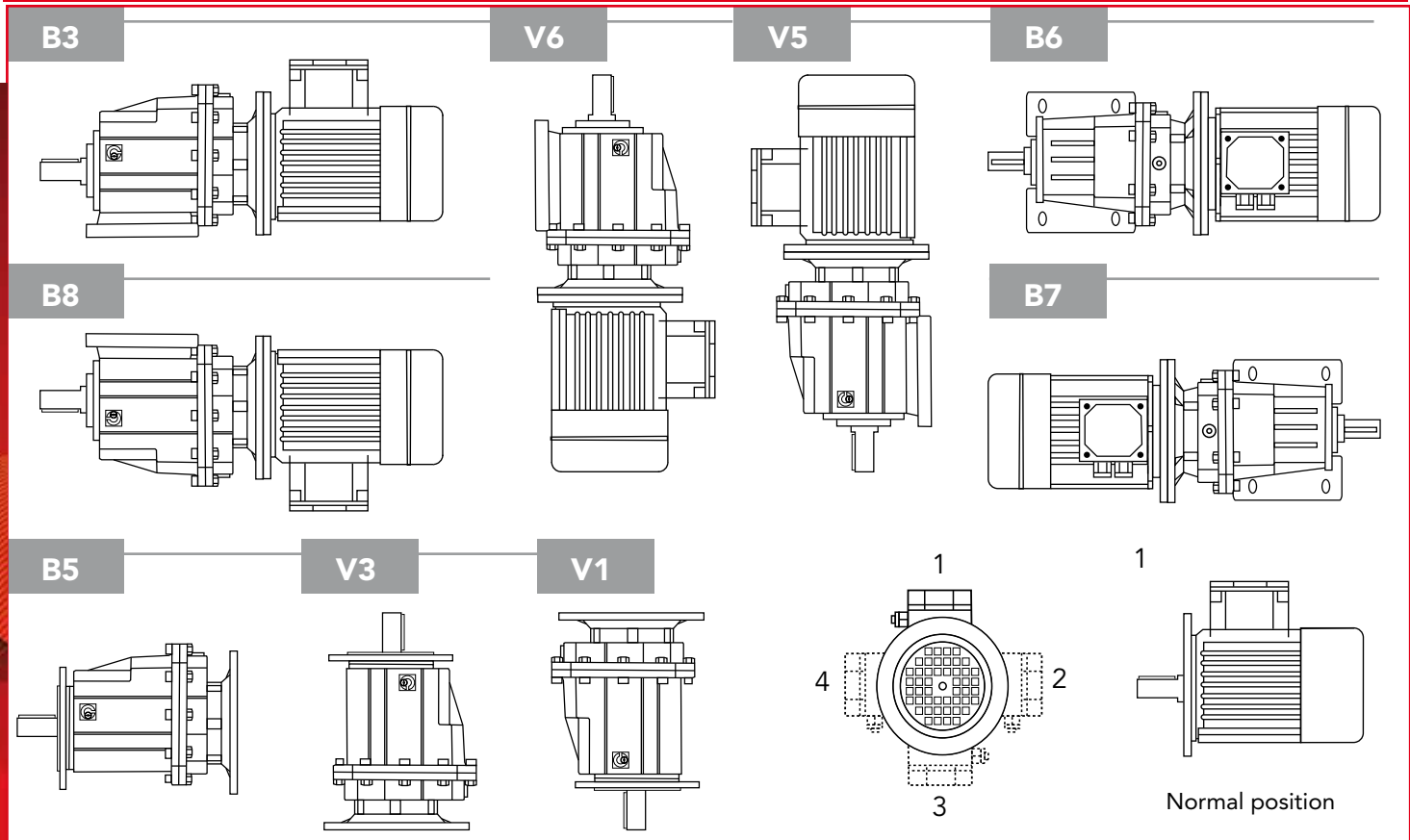

Size	Fill quantity in litres	
	STANDARD	V6/V3
CHC 16/20	0,4	0,6
CHC 25	0,5	0,7
CHC 30	0,8	1,1
CHC 35/40	1,2	1,6

The CHC gearboxes are supplied with Shell Tivela S 320 oil for STANDARD position, when mounted in V6/V3 it is necessary to add the correct quantity of oil.



RATIO AND IEC MOTOR ADAPTERS

CHC 20	(CHC16)*	IEC	
i	63B5	71B5 71B14	80B5 80B14
45,9	B		
40,1	B		
35,5	B		
28,5	B		
23,6	B		
19,8	B		
17,9	B		
13,8	B		
11,9	B		
9,8	B		
7,7	B		
5,7	B		
4,6	B	B	

CHC 25	IEC		
i	71B5 71B14	80B5 80B14	90B5 90B14
46,5	B		
40,6	B		
35,9	B		
28,9	B		
23,9	B		
20,1		B	
17,1		B	
14,8		B	
12,1		B	
9,9		B	
7,4		B	
5,5		B	

CHC 30	IEC		
i	80B5 80B14	90B5 90B14	100/112B5 100/112B14
58,1	B		
50,0	B		
43,7	B		
38,7	B		
34,6	B		
30,6	B		
25,0	B		
21,7	B	B	
17,3	B	B	
15,0	B	B	
12,3		B	
10,2		B	
7,9		B	
5,5		B	

CHC 35	CHC 40	IEC	
i	80B5 80B14	90B5 90B14	100/112B5 100/112B14
58,1	B		
50,0	B		
43,7	B		
34,6	B	B	
28,3	B	B	
21,7	B	B	
17,3	B	B	
15,1	B	B	
12,3		B	
10,2		B	
7,9		B	
5,5		B	

* CHC 16 Only on request
 Ratios are rounded
 B= Metal reduction bushing

IEC	63B5	71B5	71B14	80B5	80B14	90B5	90B14	100B5	100B14	112B5	112B14
DEB	11	14		19		24		28		28	
P	140	160	105	200	120	200	140	250	160	250	160
M	115	130	85	165	100	165	115	215	130	215	130
N	95	110	70	130	80	130	95	180	110	180	110

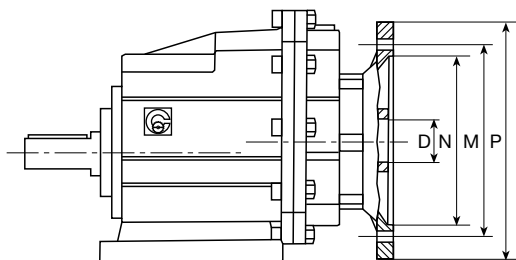

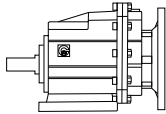
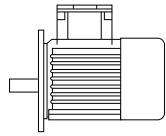

GEAR UNIT SELECTION TABLES

P_{1n} [Kw]	n_2 [r/min]	M_{2n} [Nm]	i	f_s			page				
0.12	30.5	36	45.9	3.3	CHC20	63B5	63A4	16			
	34.9	32	40.1	3.8	(CHC16)						
	39.5	28	35.5	4.3							
	49.1	22	28.5	5.4							
	59.4	18.5	23.6	6.5							
	70.6	15.6	19.8	7.7							
	78.4	14.0	17.9	7.1							
	101	10.8	13.8	9.2							
	118	9.4	11.9	12.8							
	143	7.7	9.8	13.0							
	181	6.1	7.7	13.2							
	246	4.5	5.7	13.4							
	0.18	19.6	84	45.9	1.4	CHC20	71B5/B14		71A6	16	
22.4		74	40.1	1.6	(CHC16)						
25.4		65	35.5	1.8							
31.6		52	28.5	2.3							
30.5		54	45.9	2.2	CHC20	63B5	63B4	16			
34.9		47	40.1	2.5	(CHC16)						
39.5		42	35.5	2.9							
49.1		34	28.5	3.6							
59.4		28	23.6	4.3							
70.6		23	19.8	5.1							
78.4		21	17.9	4.8							
101		16.3	13.8	6.1							
118		14.0	11.9	8.6							
143	11.6	9.8	8.6								
181	9.1	7.7	8.8								
246	6.7	5.7	8.9								
0.25	19.4	85	46.5	2.3	CHC25	71B5/B14	71A6		17		
	22.2	74	40.6	2.7							
	25.1	66	35.9	3.0							
	31.2	53	28.9	3.8							
	30.1	55	46.5	3.7	CHC25	63B5	63B4	17			
	34.5	48	40.6	4.2							
	19.6	117	45.9	1.0	CHC20	71B5/B14	71B6			16	
	22.4	102	40.1	1.2	(CHC16)						
	25.4	90	35.5	1.3							
	31.6	73	28.5	1.7							
	30.5	75	45.9	1.6	CHC20	71B5/B14	71A4				16
	34.9	66	40.1	1.8	(CHC16)						
	39.5	58	35.5	2.1							
49.1	47	28.5	2.6								
59.4	39	23.6	3.1								
70.6	32	19.8	3.7								

2D and 3D drawings available on the web site www.chiaravalli.com

Quantity, availability and prices with Chiaravalli B2B

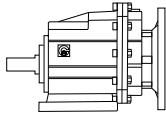
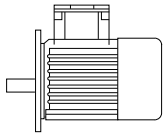
P_{1n} [Kw]	n_2 [r/min]	M_{2n} [Nm]	i	f_s				page	
0.25	78.4	29	17.9	3.4	CHC20	71B5/B14	71A4	16	
	101	23	13.8	4.4	(CHC16)				
	118	19.5	11.9	6.2					
	143	16.1	9.8	6.2					
	181	12.6	7.7	6.3					
	246	9.3	5.7	6.4					
	19.4	118	46.5	1.7	CHC25	71B5/B14	71B6	17	
	22.2	103	40.6	1.9					
	25.1	91	35.9	2.2					
	31.2	74	28.9	2.7					
	30.1	76	46.5	2.6	CHC25	71B5/B14	71A4		
	34.5	66	40.6	3.0					
0.37	39.0	59	35.9	3.4					
	48.5	47	28.9	4.2					
	30.5	111	45.9	1.1	CHC20	71B5/B14	71B4	16	
	34.9	97	40.1	1.2	(CHC16)				
	39.5	86	35.5	1.4					
	49.1	69	28.5	1.7					
	59.4	57	23.6	2.1					
	70.6	48	19.8	2.5					
	78.4	43	17.9	2.3					
	101	33	13.8	3.0					
	118	29	11.9	4.2					
	143	24	9.8	4.2					
	181	19	7.7	4.3					
	246	14	5.7	4.4					
	19.4	175	46.5	1.1	CHC25	80B4/B14	80A6		17
	22.2	153	40.6	1.3					
	25.1	135	35.9	1.5					
	31.2	109	28.9	1.8					
	30.1	113	46.5	1.8	CHC25	71B5/B14	71B4		
	34.5	98	40.6	2.0					
	39	87	35.9	2.3					
	48.5	70	28.9	2.9					
	58.7	58	23.8	3.5					
	81.9	41	17.1	3.9					
	15.5	219	58.1	1.4	CHC30	80B5/B14	80A6	18	
	18.0	189	50.0	1.6					
	21.0	165	43.7	1.8					
	0.55	101	50	13.8	2.0	CHC20	80B5/B14	80A4	16
		118	43	11.9	2.8	(CHC16)			
143		35	9.8	2.8					
181		28	7.7	2.9					
246		20	5.7	2.9					

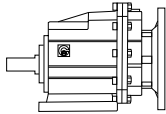
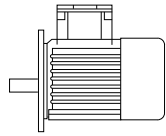

GEAR UNIT SELECTION TABLES

P_{1n} [Kw]	n_2 [r/min]	M_{2n} [Nm]	i	f_s			page		
0.55	19.4	260	46.5	0.8	CHC25	80B5/B14	80B6	17	
	22.2	227	40.6	0.9					
	25.1	201	35.9	1.0					
	31.2	162	28.9	1.2					
	37.7	134	23.9	1.5					
	30.1	167	46.5	1.2	CHC25	80B5/B14	80A4	17	
	34.5	146	40.6	1.4					
	39	129	35.9	1.5					
	48.5	104	28.9	1.9					
	58.7	86	23.9	2.3					
	69.7	72	20.1	2.8					
	81.9	62	17.1	2.6					
	94.5	53	14.8	3.7					
		15.5	325	58.1	0.9	CHC30	80B5/B14	80B6	18
18.0		280	50.0	1.1					
21.0		245	43.7	1.2					
23.0		217	38.7	1.4					
24.0		209	58.1	1.4	CHC30	80B5/B14	80A4	18	
28.0		180	50.0	1.7					
32.0		158	43.7	1.9					
36.0		139	38.7	2.2					
0.75		101	68	13.8	1.5	CHC20	80B5/B14	80B4	16
		118	58	11.9	2.1	(CHC16)			
	143	48	9.8	2.1					
	181	38	7.7	2.1					
	246	28	5.7	2.1					
	302	23	4.6	2.6					
	30.1	228	46.5	0.9	CHC25	80B5/B14	80B4	17	
	34.5	199	40.6	1.0					
	39	176	35.9	1.1					
	48.5	142	28.9	1.4					
	58.7	117	23.9	1.7					
	69.7	99	20.1	2.0					
	81.9	84	17.1	1.9					
	94.5	73	14.8	2.7					
	116.2	59	12.1	3.4					
	141	49	9.9	3.3					
	189	36	7.4	3.3					
	257	27	5.5	3.7					
	23.3	296	38.7	1.0	CHC30	90B5/B14	90S6	18	
	26.0	264	34.6	1.1					
	29.4	234	30.6	1.3					
	36	191	25.0	1.6					
	24.0	285	58.1	1.1	CHC30	80B5/B14	80B4	18	

2D and 3D drawings available on the web site www.chiaravalli.com

Quantity, availability and prices with Chiaravalli B2B

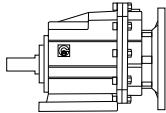
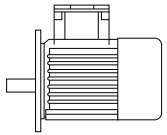
P_{1n} [Kw]	n_2 [r/min]	M_{2n} [Nm]	i	f_s				page
0.75	28.0	246	50.0	1.2	CHC30	80B5/B14	80B4	18
	32.0	215	43.7	1.4				
	36.2	190	38.7	1.6				
	40.5	160	34.6	1.8				
	45.8	150	30.6	2.0				
	56.0	123	25.0	2.4				
	64.5	107	21.7	2.6				
	15.5	444	58.1	1.1	CHC35	90B5/B14	90S6	19
	18.0	382	50.0	1.3	CHC40			
	20.6	334	43.7	1.5				
26.0	264	34.6	1.9					
24.0	285	58.1	1.8	CHC35	80B5/B14	80B4	19	
28.0	246	50.0	2.0	CHC40				
32.0	215	43.7	2.3					
1.1	101	99	13.8	1.0	CHC20	80B5/B14	80C4	16
	118	86	11.9	1.4	(CHC16)			
	143	71	9.8	1.4				
	181	56	7.7	1.4				
	246	41	5.7	1.5				
	302	33	4.6	1.8				
	48.5	208	28.9	1.0	CHC25	80B5/B14	80C4	17
	58.7	172	23.9	1.2				
	69.7	145	20.1	1.4	CHC25	90B5/B14	90S4	17
	81.9	123	17.1	1.3				
	94.5	107	14.8	1.9				
	116	87	12.1	2.3				
	141	72	9.9	2.2				
	189	53	7.4	2.3				
	257	39	5.5	2.5				
	32.0	315	43.7	0.9	CHC30	90B5/B14	90S4	18
	36.2	279	38.7	1.1				
	40.4	249	34.6	1.2				
	45.8	220	30.6	1.4				
	56.0	180	25.0	1.7				
64.5	157	21.7	1.8					
81.0	125	17.3	2.2					
24.0	418	58.1	1.2	CHC35	90B5/B14	90S4	19	
28.0	360	50.0	1.4	CHC40				
32.0	315	43.7	1.6					
40.5	249	34.6	2.0					
49.5	204	28.3	2.5					
64.5	157	21.7	3.1					
81.0	125	17.3	3.8					
92.7	108	15.1	4.2					

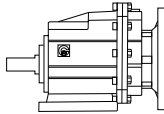
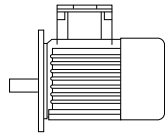

GEAR UNIT SELECTION TABLES

P_{1n} [Kw]	n_2 [r/min]	M_{2n} [Nm]	i	f_s				page
1.5	69.7	197	20.1	1.0	CHC25	90B5/B14	90L4	17
	81.9	168	17.1	1.0				
	94.5	145	14.8	1.4				
	116	118	12.1	1.7				
	141	98	9.9	1.6				
	189	73	7.4	1.7				
1.5	257	54	5.5	1.9	CHC25	90B5/B14	90L4	17
	40.4	340	34.6	0.9	CHC30	90B5/B14	90L4	18
	45.8	300	30.6	1.0				
	56	245	25.0	1.2				
	64.5	214	21.7	1.3				
	81.0	170	17.3	1.6				
	93.0	148	15.0	1.8				
	113.8	122	12.3	2.1				
	136.0	101	10.3	2.4				
	177	78	7.9	2.3				
	255	54	5.5	2.8				
	26.0	529	34.6	0.9	CHC35	100B5/B14	100L6	19
	31.8	432	28.3	1.2	CHC40			
	41,5	333	21.7	1.4				
	24.0	571	58.1	0.9	CHC35	90B5/B14	90L4	19
28.0	491	50.0	1.0	CHC40				
32.0	430	43.7	1.2					
40.4	340	34.6	1.5					
49.5	278	28.3	1.8					
64.5	214	21.7	2.2					
81.0	170	17.3	2.8					
92.7	148	15.1	3.1					
2.2	81.0	250	17.3	1.1	CHC30	100B5/B14	100LA4	18
	93.0	217	15.0	1.2				
	113.8	178	12.3	1.5				
	136.0	148	10.2	1.6				
	177	114	7.9	1.6				
	255	79	5.5	1.9				
	41.5	488	21.7	1.0	CHC35	112B5/B14	112M6	19
	52.0	388	17.3	1.2	CHC40			
	59.6	338	15.1	1.4				
	40.4	499	34.6	1.0	CHC35	100B5/B14	100LA4	19
	49.5	408	28.3	1.2	CHC40			
	64.5	314	21.7	1.5				
	81.0	250	17.3	1.9				
	92.7	217	15.1	2.1				
	113.8	178	12.3	2.6				
136.0	148	10.2	3.0					

2D and 3D drawings available on the web site www.chiaravalli.com

Quantity, availability and prices with Chiaravalli B2B



PERFORMANCE PARAMETER $f \cdot s = 1$

M_{2max} [Nm]	n_1 [r/min]	i	P_{1n} [Kw]	n_2 [r/min]	
120	1400	45.9	0.40	30.5	CHC20
120	1400	40.1	0.46	34.9	(CHC16)
120	1400	35.5	0.52	39.5	
120	1400	28.5	0.64	49.1	
120	1400	23.6	0.78	59.4	
120	1400	19.8	0.92	70.6	
90	1400	17.9	0.77	78.4	
90	1400	13.8	1.00	101	
120	1400	11.9	1.54	118	
120	1400	9.8	1.87	143	
80	1400	7.7	1.58	181	
70	1400	5.7	1.88	246	
70	1400	4.6	2.31	302	
200	1400	46.5	0.66	30.1	CHC25
200	1400	40.6	0.75	34.5	
200	1400	35.9	0.85	39.0	
200	1400	28.9	1.06	48.5	
200	1400	23.9	1.28	58.7	
200	1400	20.1	1.52	69.7	
140	1400	17.1	1.25	81.9	
200	1400	14.8	2.06	94.6	
200	1400	12.1	2.53	116	
200	1400	9.9	3.08	141	
120	1400	7.4	2.49	190	
100	1400	5.5	2.80	257	
300	1400	58.1	0.79	24.0	CHC30
300	1400	50.0	0.92	28.0	
300	1400	43.7	1.04	32.0	
300	1400	38.7	1.18	36.1	
300	1400	34.6	1.32	40.5	
300	1400	30.6	1.50	45.8	
300	1400	25.0	1.83	56.0	
280	1400	21.7	1.96	64.5	
280	1400	17.3	2.47	81.0	
260	1400	15.0	2.64	93.0	
260	1400	12.3	3.21	113.8	
240	1400	10.2	3.57	137.0	
180	1400	7.9	3.46	176	
150	1400	5.5	4.17	255	
500	1400	58.1	1.31	24.0	CHC35
500	1400	50.0	1.53	28.0	CHC40
500	1400	43.7	1.75	32.0	
500	1400	34.6	2.21	40.5	
500	1400	28.3	2.70	49.5	
480	1400	21.7	3.37	64.5	
480	1400	17.3	4.23	81.0	
460	1400	15.1	4.66	93.0	
460	1400	12.3	5.68	113.8	
440	1400	10.2	6.54	136.0	
260	1400	7.9	5.01	177	
230	1400	5.5	6.41	255	



DIMENSION SHEET

CHC 20 (CHC16) P (IEC)

INPUT

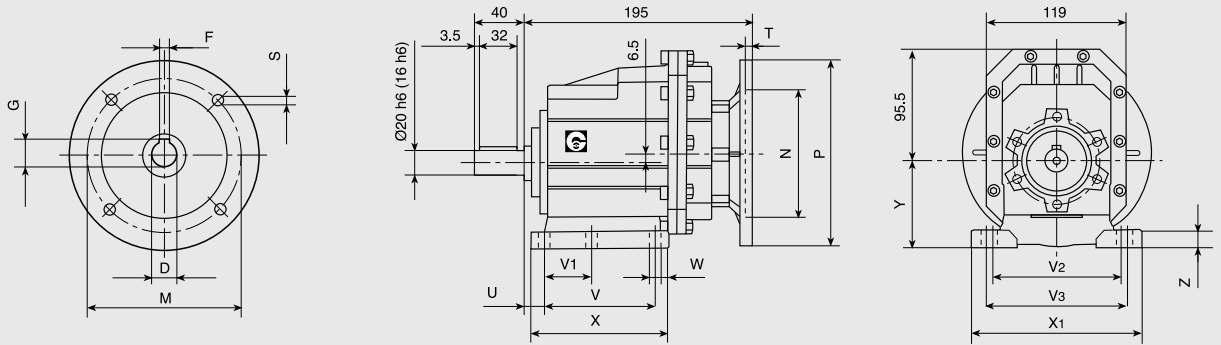

CHC 20 (CHC16) F (IEC)

OUTPUT

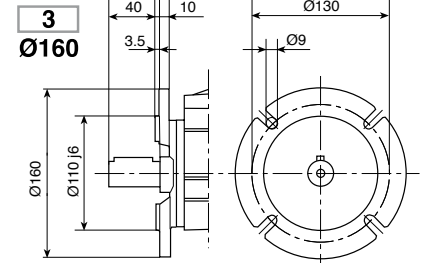
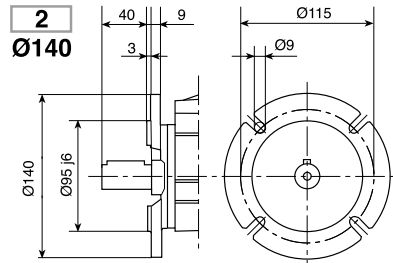
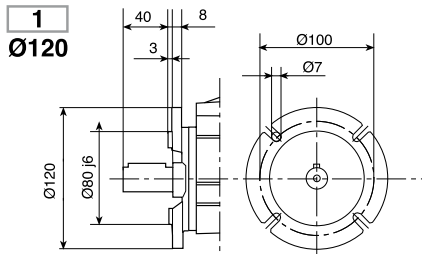
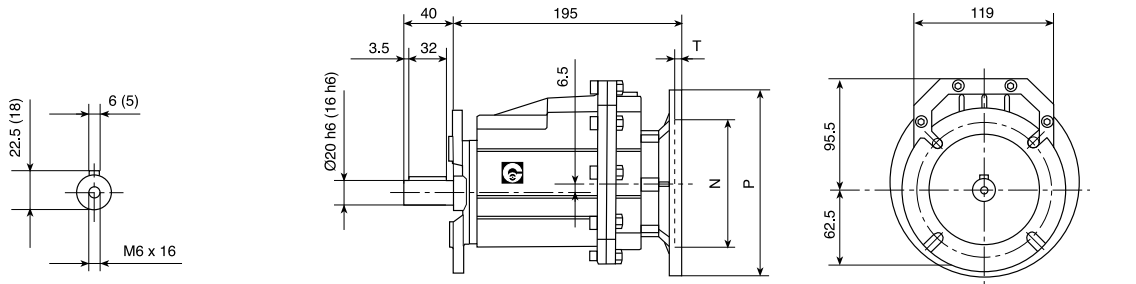

CHC 20 (CHC16) (IEC)

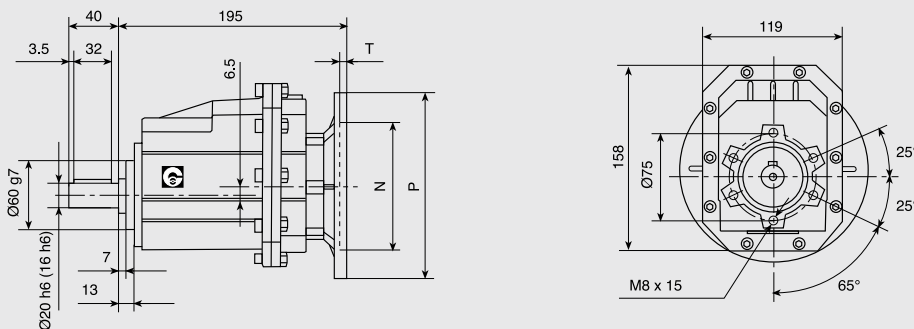

(CHC16) On request

kg. 4,7

IEC	D	F	G	P	M	N	S	T
63B5	11	4	12.8	140	115	95	9	5
71B5	14	5	16.3	160	130	110	9	5
71B14	14	5	16.3	105	85	70	7	5
80B5	19	6	21.8	200	165	130	11	5
80B14	19	6	21.8	120	100	80	7	5

Foot cod.	U	V	V ₁	V ₂	V ₃	W	X	X ₁	Y	Z
B	18	87	50	110	-	9	118	130	85	15
M	18	80	-	110	120	9	118	145	75	15

2D and 3D drawings available on the web site www.chiaravalli.com

Quantity, availability and prices with Chiaravalli B2B



DIMENSION SHEET

CHC 25 P (IEC)

INPUT

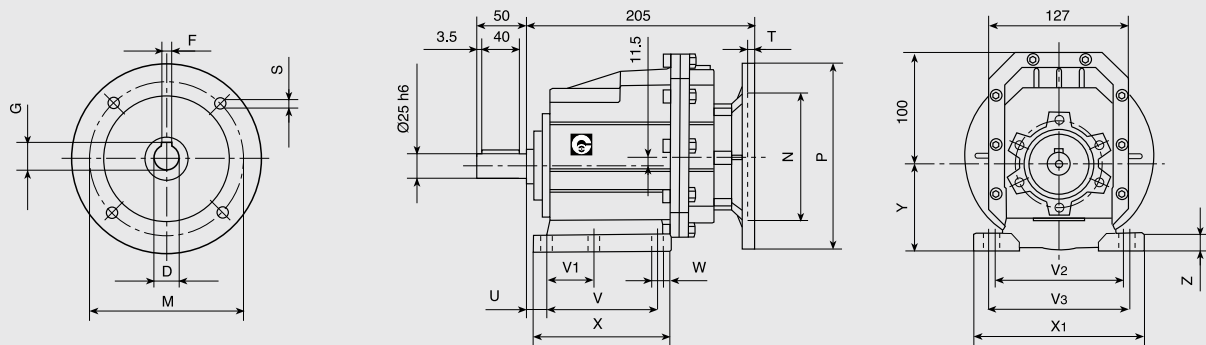

CHC 25 F (IEC)

OUTPUT

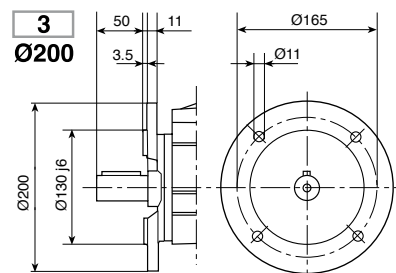
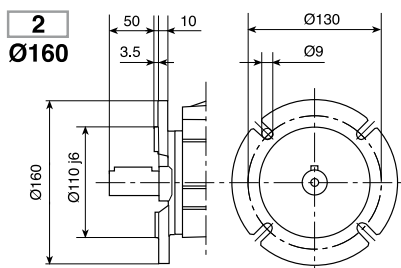
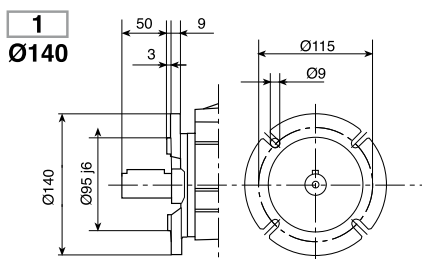
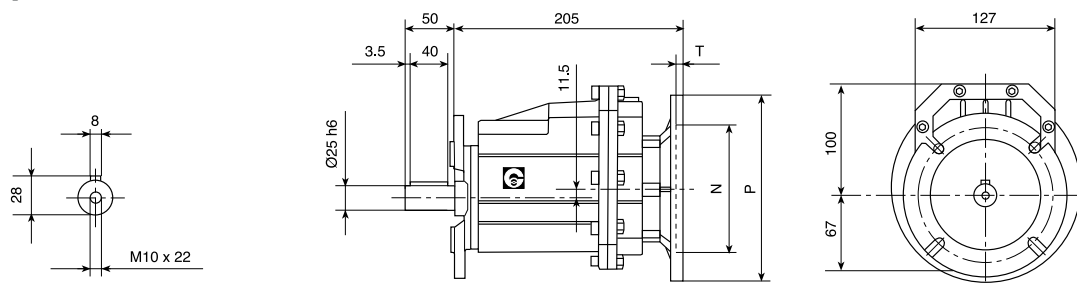

CHC 25 (IEC)

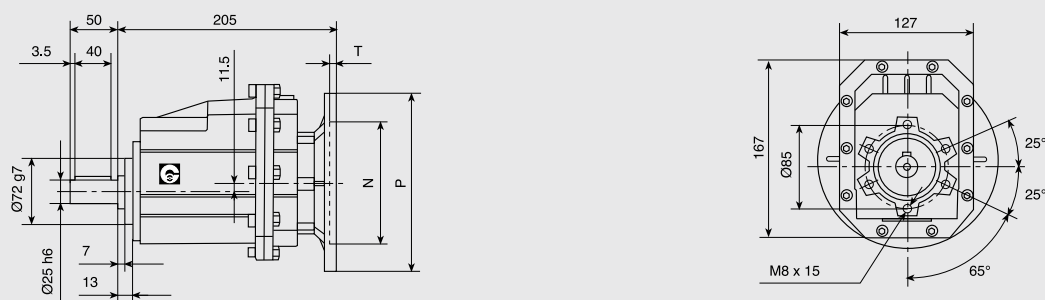

kg. 5,8

Foot cod.	U	V	V ₁	V ₂	V ₃	W	X	X ₁	Y	Z
B	18	107,5	60	-	130	11	136	155	100	17
M	25	85	-	110	120	9	112	145	80	15

IEC	D	F	G	P	M	N	S	T
71B5	14	5	16.3	160	130	110	9	5
71B14	14	5	16.3	105	85	70	7	5
80B5	19	6	21.8	200	165	130	11	5
80B14	19	6	21.8	120	100	80	7	5
90B5	24	8	27.3	200	165	130	11	5
90B14	24	8	27.3	140	115	95	9	5

2D and 3D drawings available on the web site www.chiaravalli.com

Quantity, availability and prices with Chiaravalli B2B



DIMENSION SHEET

CHC 30 P (IEC)

INPUT

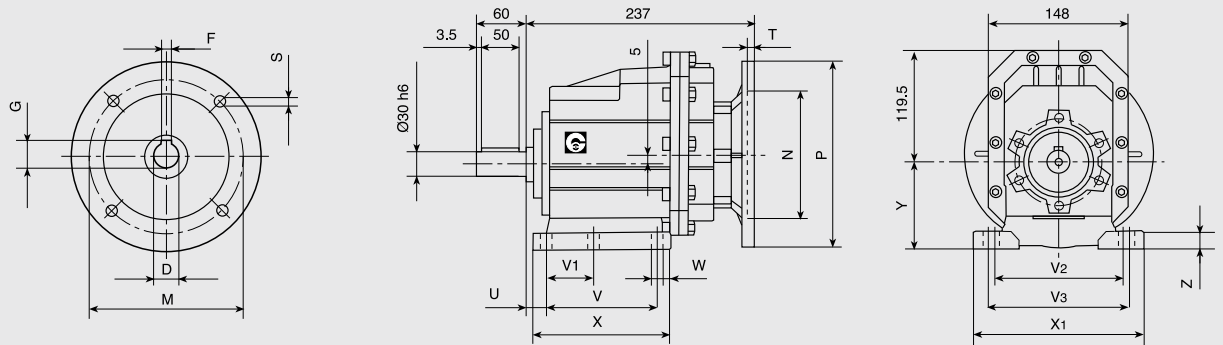

CHC 30 F (IEC)

OUTPUT

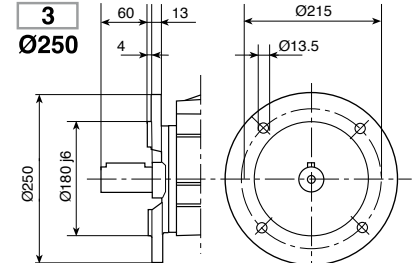
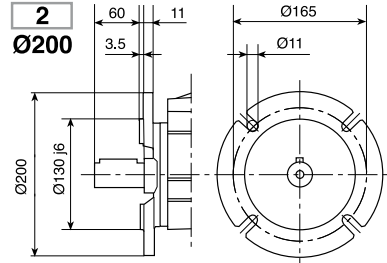
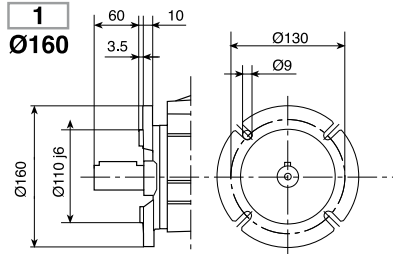
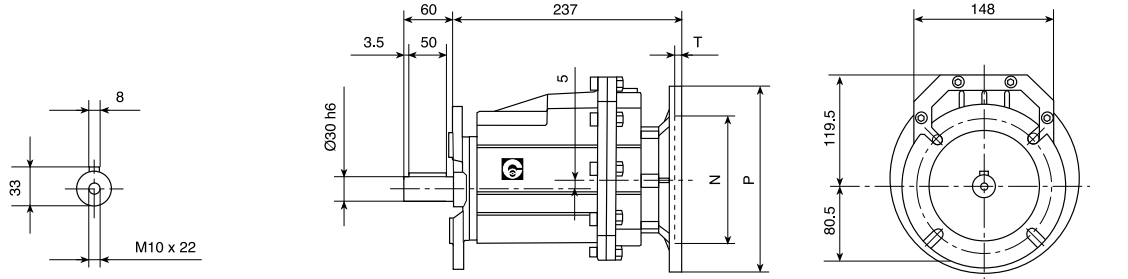

CHC 30 (IEC)

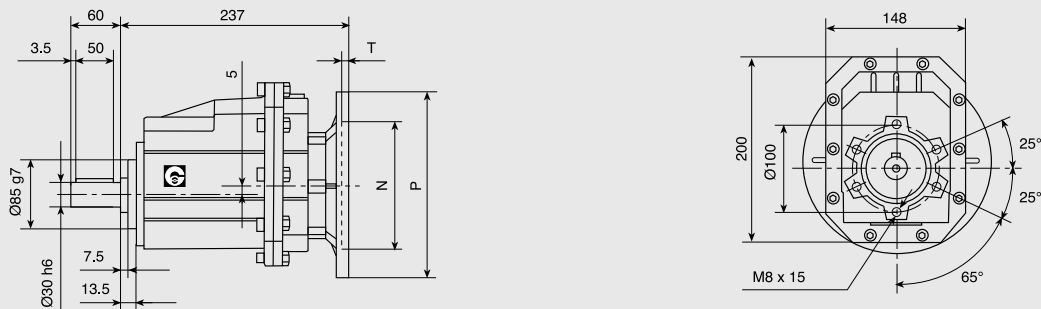

kg. 9,2

IEC	D	F	G	P	M	N	S	T
80B5	19	6	21.8	200	165	130	11	5
80B14	19	6	21.8	120	100	80	7	5
90B5	24	8	27.3	200	165	130	11	5
90B14	24	8	27.3	140	115	95	9	5
100/112B5	28	8	31.3	250	215	180	13.5	5
100/112B14	28	8	31.3	160	130	110	9	5

Foot cod.	U	V	V1	V2	V3	W	X	X1	Y	Z
B	18	130	70	-	160	11	156	190	110	20
M	30	100	-	135	150	11	150	190	110	18



CHC 35 - CHC 40 P (IEC)

INPUT

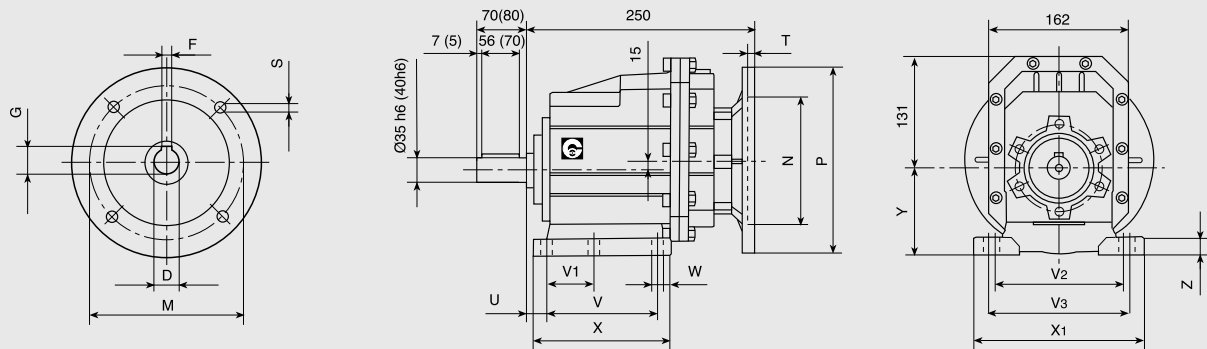

CHC 35 - CHC 40 F (IEC)

OUTPUT

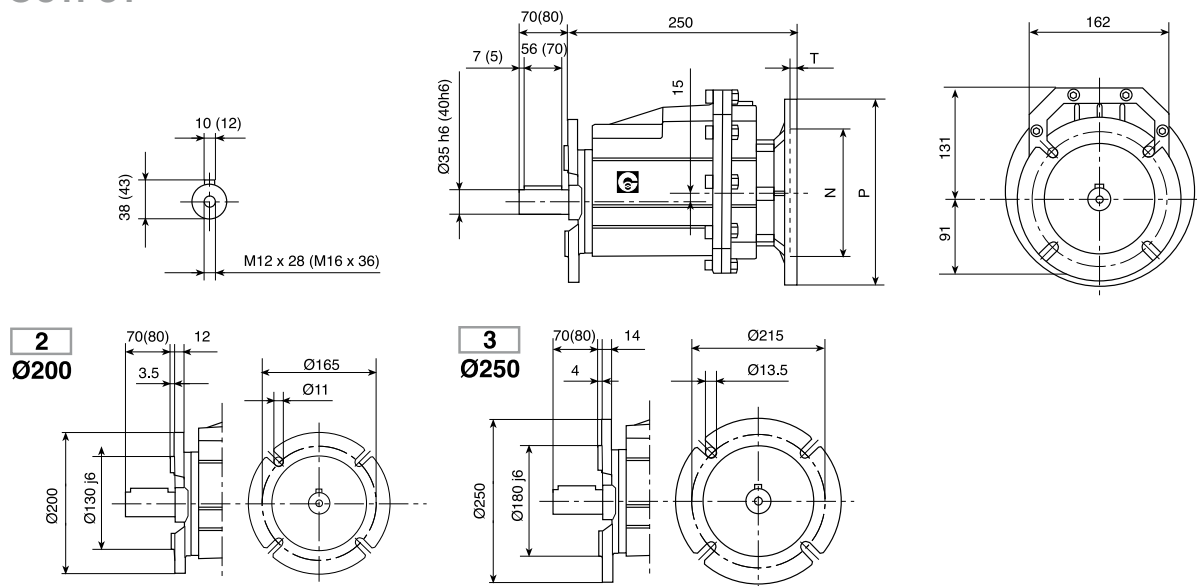

CHC 35 - CHC 40 (IEC)

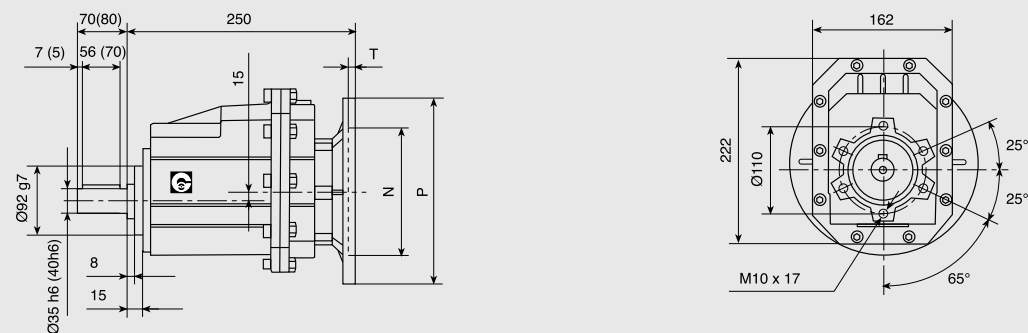

kg. 12,2

Foot cod.	U	V	V ₁	V ₂	V ₃	W	X	X ₁	Y	Z
B	23.5	130	-	170	-	14	168	205	115	20
C	19.5	149.5	-	180	-	14	185	215	130	20
M	35	110	-	170	185	14	150	230	120	20

IEC	D	F	G	P	M	N	S	T
80B5	19	6	21.8	200	165	130	11	5
80B14	19	6	21.8	120	100	80	7	5
90B5	24	8	27.3	200	165	130	11	5
90B14	24	8	27.3	140	115	95	9	5
100/112B5	28	8	31.3	250	215	180	13.5	5
100/112B14	28	8	31.3	160	130	110	9	5

(...) Between brackets CHC 40 dimension

2D and 3D drawings available on the web site www.chiaravalli.com
Quantity, availability and prices with Chiaravalli B2B



EXPLODED DRAWING AND SPARE PARTS LIST

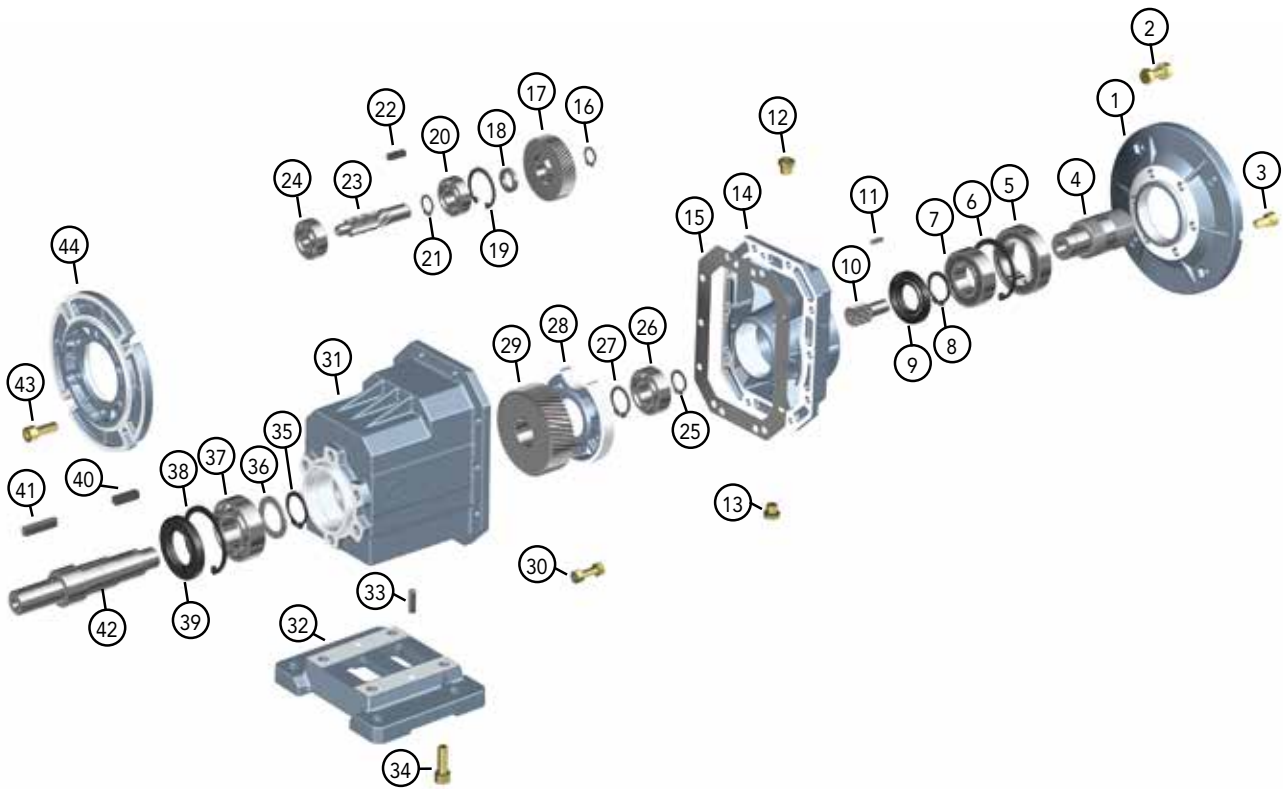

1	MOTOR CONNECTION FLANGE	23	SECOND REDUCTION PINION
2	SCREW WITH NUT	24	BEARING
3	HEXAGONAL-HEAD SCREW	25	SEEGER
4	HOLE INPUT SHAFT	26	BEARING
5	BEARING	27	SEEGER
6	SEEGER	28	INTERNAL SUPPORT
7	BEARING	29	SECOND REDUCTION GEAR
8	SEEGER	30	SCREW WITH NUT
9	OIL SEAL	31	HOUSING
10	FIRST REDUCTION PINION	32	FOOT KIT
11	KEY	33	DOWEL PIN
12	OIL PLUG	34	HEXAGONAL-HEAD SCREW
13	OIL PLUG	35	SEEGER
14	COVER	36	SPACER
15	GASKET	37	BEARING
16	SEEGER	38	SEEGER
17	FIRST REDUCTION GEAR	39	OIL SEAL
18	SPACER	40	KEY
19	SEEGER	41	KEY
20	BEARING	42	OUTPUT SHAFT
21	SEEGER	43	HEXAGONAL-HEAD SCREW
22	KEY	44	OUTPUT FLANGE



INSTALLATION

- The data shown on the identification name plate must correspond to the gearbox ordered.
- The oil level must correspond to the quantity foreseen for the assembly position requested (see catalogue).
- All of the other gearboxes are supplied complete with permanent synthetic oil in a quantity that is sufficient for any assembly position.
- The gearbox must be fixed on a flat surface that is sufficiently rigid in order to avoid any vibration.
- The gearbox and the axis of the machine to be driven must be perfectly aligned o in the event that knocks, overloading or blockage of the machine are foreseen, the client must install a limiting device, joints, overload cut-out etc.
- Coupling with pinions, joints, pulleys and other parts must be done after the parts have been cleaned and knocks should be avoided while assembling as they could damage the bearings and other internal parts.
- In the event that the motor is supplied by the client, he must check that the flange and shaft tolerances correspond to a "normal" class; our motors satisfy this requirement.
- Check that the fixing screws for the gear and the related accessories are correctly tightened.
- Take suitable measures to protect the groups from any aggressive atmospheric agents.
- Where foreseen, protect rotating parts from any possible contact with the operators.
- If the gears are painted, protect the oil seals and the machined surfaces gearboxes.
- All of the gears are painted RAL 9022 grey.

OPERATION AND RUNNING-IN

- To obtain the best performance the gearboxes must first be run-in by gradually increasing the power in the first few hours of operation, in this phase an increase in temperature is considered normal.
- In the event of defective operation, noise, oil leakage, etc. stop the gear immediately and, when possible, remove the cause. Alternatively, send the piece to our factory to be controlled.

MAINTENANCE

- The helical gearboxes are lubricated with permanent synthetic oil and therefore do not require any maintenance.

WAREHOUSE STORAGE

- If the warehouse storage will be for a long time, more than 3 months, the shafts and machined surfaces should be protected using antioxidants and the oil seals should be greased.

HANDLING

- Care must be taken not to damage the oil seals and the machined surfaces when handling the groups.

DISPOSAL OF PACKAGING

- The packaging in which our gears are delivered should be sent to specialised companies for recycling if possible.